

**Impact™
Daughtercard
Removal Tool**

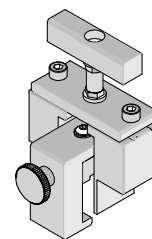

**Application Tooling
Specification Sheet**



Order No. 62100-8080

FEATURES

- This tool is designed for the removal of an Impact™ Daughtercard signal module from a PCB
- This tool will not remove the Impact™ right-angle-male (RAM) signal module (use tool 66602-4350)
- Use tool 66601-8659 for inserting 5 pair by 16 column Daughtercard assemblies

SCOPE

Products: Impact™ Daughtercard signal module, 5 Pair x 16 columns. See Product List below for order numbers.

Product List

The following is a partial list of the product order numbers and their specifications this tool is designed to run. Updates to this list are available on www.molex.com.

Series No.	Guide Style	Columns	5 Pair Assembly Order Number							
76060	Open	16	76060-0016	76060-1016	76060-0026	76060-1026				
	Left	16	76060-2016	76060-2026	76060-2056	76060-2066	76060-2116	76060-2126		
			76060-2156	76060-2166	76060-2216	76060-2226	76060-2256	76060-2266		
			76060-2316	76060-2326	76060-2356	76060-2366	76060-2416	76060-2426		
			76060-2456	76060-2466	76060-2516	76060-2526	76060-2556	76060-2566		
			76060-2616	76060-2626	76060-2656	76060-2666	76060-2716	76060-2726		
			76060-2756	76060-2766	76060-2816	76060-2826	76060-2856	76060-2866		
			76060-3016	76060-3026	76060-3056	76060-3066	76060-3116	76060-3126		
			76060-3156	76060-3166	76060-3216	76060-3226	76060-3256	76060-3266		
			76060-3316	76060-3326	76060-3356	76060-3366	76060-3416	76060-3426		
			76060-3456	76060-3466	76060-3516	76060-3526	76060-3556	76060-3566		
			76060-3616	76060-3626	76060-3656	76060-3666	76060-3716	76060-3726		
			76060-3756	76060-3766	76060-3816	76060-3826	76060-3856	76060-3866		
			Right	16	76060-4016	76060-4026	76060-4056	76060-4066	76060-4116	76060-4126
					76060-4156	76060-4166	76060-4216	76060-4226	76060-4256	76060-4266
	76060-4316	76060-4326			76060-4356	76060-4366	76060-4416	76060-4426		
	76060-4456	76060-4466			76060-4516	76060-4526	76060-4556	76060-4566		
	76060-4616	76060-4626			76060-4656	76060-4666	76060-4716	76060-4726		
	76060-4756	76060-4766			76060-4816	76060-4826	76060-4856	76060-4866		
	76060-5016	76060-5026			76060-5056	76060-5066	76060-5116	76060-5126		
	76060-5156	76060-5166			76060-5216	76060-5226	76060-5256	76060-5266		
	76060-5316	76060-5326			76060-5356	76060-5366	76060-5416	76060-5426		
	76060-5456	76060-5466			76060-5516	76060-5526	76060-5556	76060-5566		
	76060-5616	76060-5626			76060-5656	76060-5666	76060-5716	76060-5726		
	76060-5756	76060-5766			76060-5816	76060-5826	76060-5856	76060-5866		

DESCRIPTION

Figure 1 illustrates the principal parts of the removal tool.

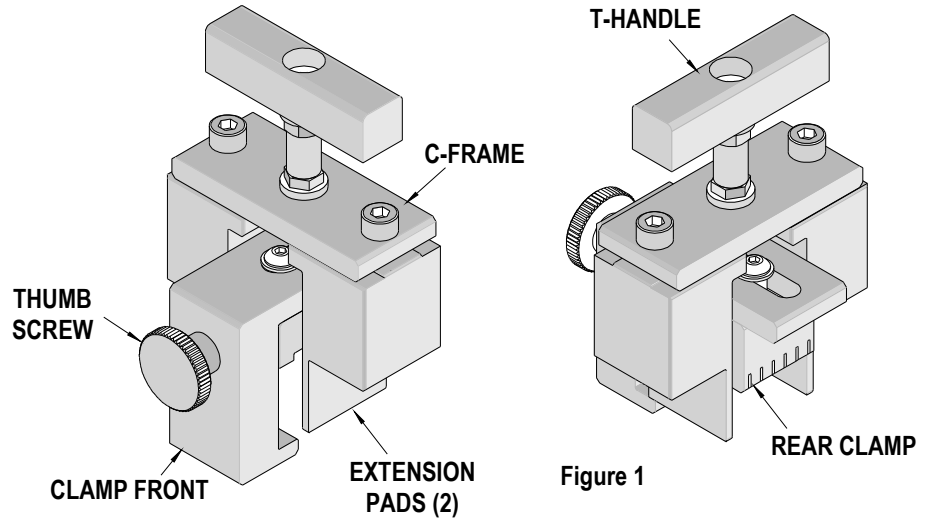

Figure 1

Tool Restrictions

These tools require a “Keep Out Zone” on the open side of the Daughtercard free of components. The right and left sides should be 3mm (0.12 in). See Figure 2. This is a general requirement, regardless of the module being removed.

Note: Be sure that all parts of the removal tool will clear any components on the printed circuit board during use. Tape may also be placed over circuit traces or on the bottom of the Extension Pads for added protection of the printed circuit board.

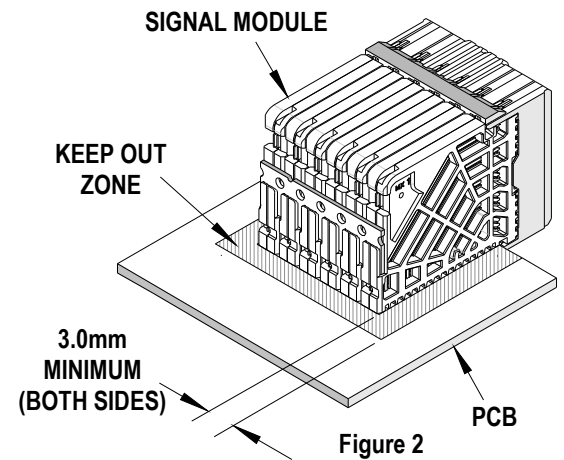

Figure 2

Tool Operation

1. Turn the T-handle counter clockwise until the clamp assembly is free of the upper frame.
2. Turn the thumb screw counter clockwise so the clamp front can open to fit over the Daughtercard shroud. See Figure 3.
3. Position the rear clamp so it is flush with the side of the outer wafer. The “teeth” of the rear clamp should fit snugly in the cut-outs of the wafers. See Figure 4.
4. Turn the thumb screw clockwise to close the clamp tightly against the Daughtercard.
5. Position the tool frame over the closed clamp and turn the T-handle clockwise until the Extension Pads contact the PCB surface. See figure 5.
6. Continue turning the T-handle clockwise until the Daughtercard is free from the PCB.
7. Move the extraction tool away from the PCB. Turn the thumb screw counterclockwise to open the clamp and Daughtercard from the extractor tool. Discard the Daughtercard module.

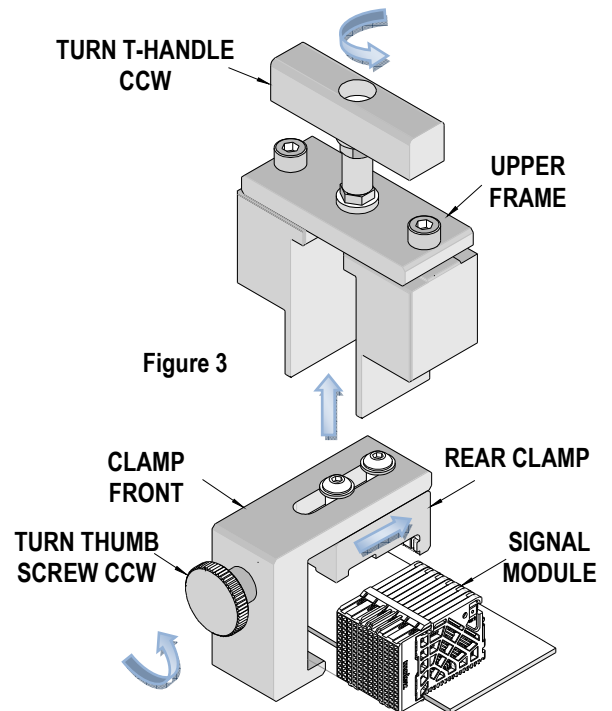
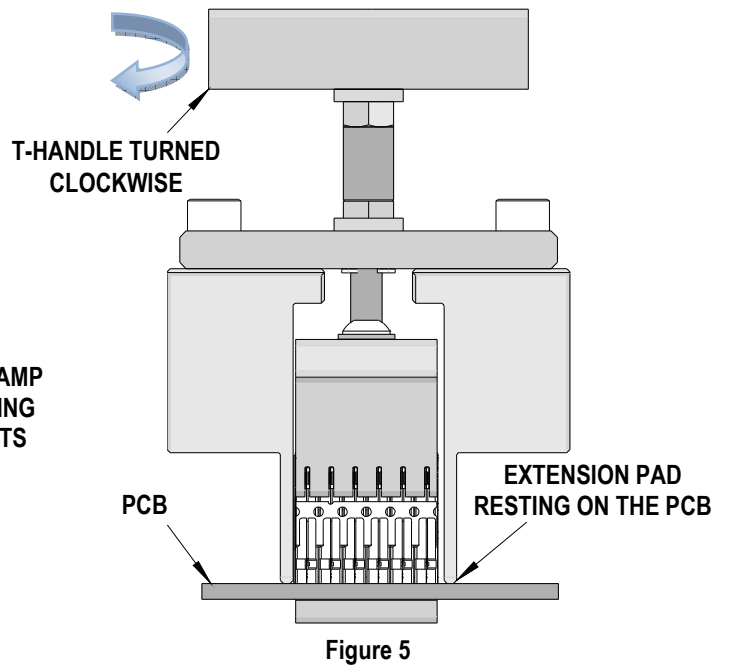
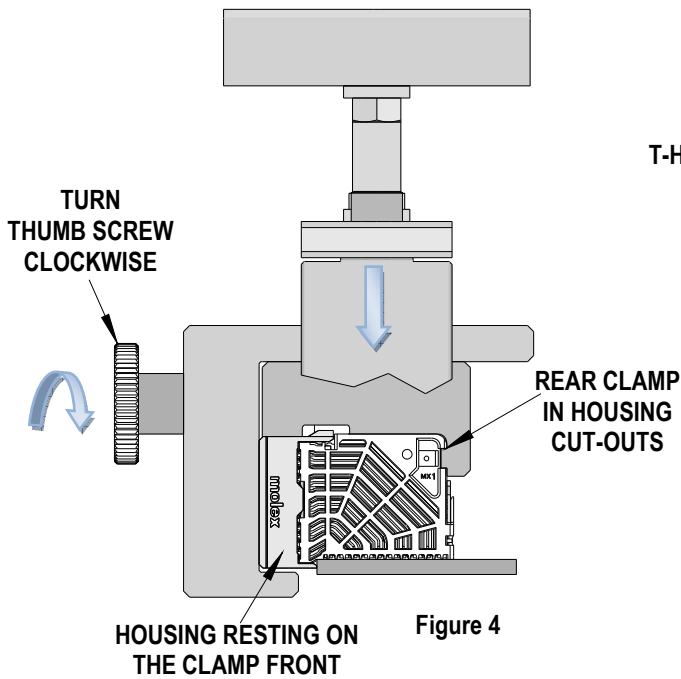

Figure 3



**Daughtercard Module Assembly Removal
(When mounted alongside other Daughtercard)**

When Daughtercard modules are stacked end to end on one side the extractor tool can be adjusted to allow the removal of the desired Daughtercard module.

1. Remove the M5 x 10 long SHCS on the side where the extra module is located. See Figure 6.
2. Rotate the Extension Pad 180°.
3. Reinstall the Extension Pad with the M5 x 10 long SHCS.
4. Follow the Tool Operation procedure for Daughtercard removal.

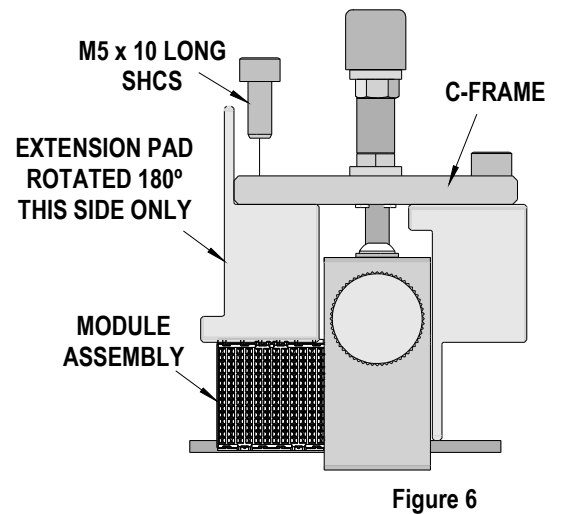

**Daughtercard Module Assembly Removal
(With Daughtercard assemblies on both sides)**

When Daughtercard modules are stacked end to end on both sides, the extractor tool can be adjusted to allow the removal of the middle Daughtercard module.

1. Remove the M5 x 14 long SHCS on each the side where the extra modules are located. See Figure 7.
2. Rotate the Extension Pads 180°.
3. Reinstall the Extension Pads with the M5 x 10 long SHCS.
4. Follow the Tool Operation procedure for Daughtercard removal.

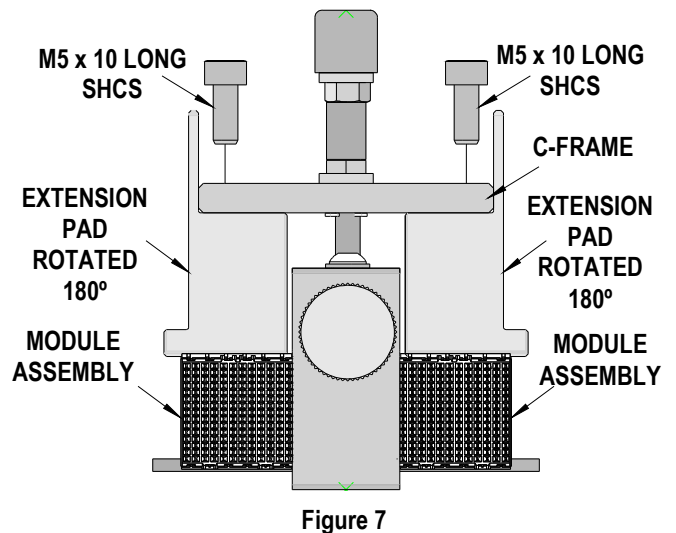

Daughtercard with Guide Module Assembly Removal

When removing a Daughtercard with a Guide module the extractor tool can be adjusted for the additional space of the guide module.

1. Remove the M5 x 10 long SHCS on the side where the guide module is located.
2. Move the Extension Pad out on this side. See Figure 8.
3. Align the second threaded hole in the extension pad with the C-frame.
4. Reinstall the M5 x 10 long SHCS thru the C-frame.

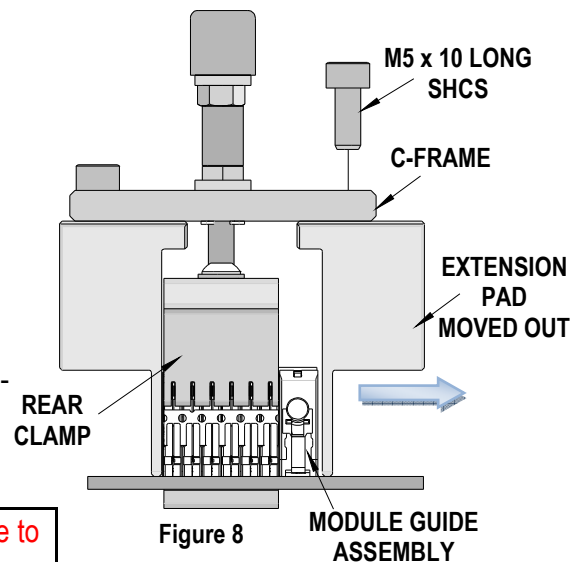

NOTE: Remember to remove the screw holding the guide module to the PCB before removing the Daughtercard module.

5. Follow the Tool Operation procedure for Daughtercard removal.

Maintenance

It is recommended that each operator of the tool be made aware of, and responsible for, the following maintenance steps:

1. Remove dust, moisture, and other contaminants with a clean brush, or soft, lint free cloth.
2. Do not use any abrasive materials that could damage the tool.
3. Make certain all pins; pivot points and bearing surfaces are protected with a thin coat of high quality machine oil. Do not oil excessively.
4. When tool is not in use, store in a clean, dry area.

CAUTION: Molex specifications are valid only when used with Molex terminals, applicators and tooling.

Contact Information

For more information on Molex application tooling please contact Molex at 1-800-786-6539.

Visit our Web site at <http://www.molex.com>